

Heavy V™



Features

- Heavy duty, crush-proof construction -- designed for decades of use
- Fast installation - pre-drilled ground plate. Fasten with 3/8" x 2-3/4" Rawl Pins or 3/8" x 4" anchor bolts into concrete roadway
- Compatible with all 4" and 6" V groove wheels
- Alternative lengths: 5', 10', 20'
- Proven in 100's of heavy duty installations: Fire trucks, refuse collection equipment and mobile cranes
- Made in the USA with US steel



TORXUN Heavy V™

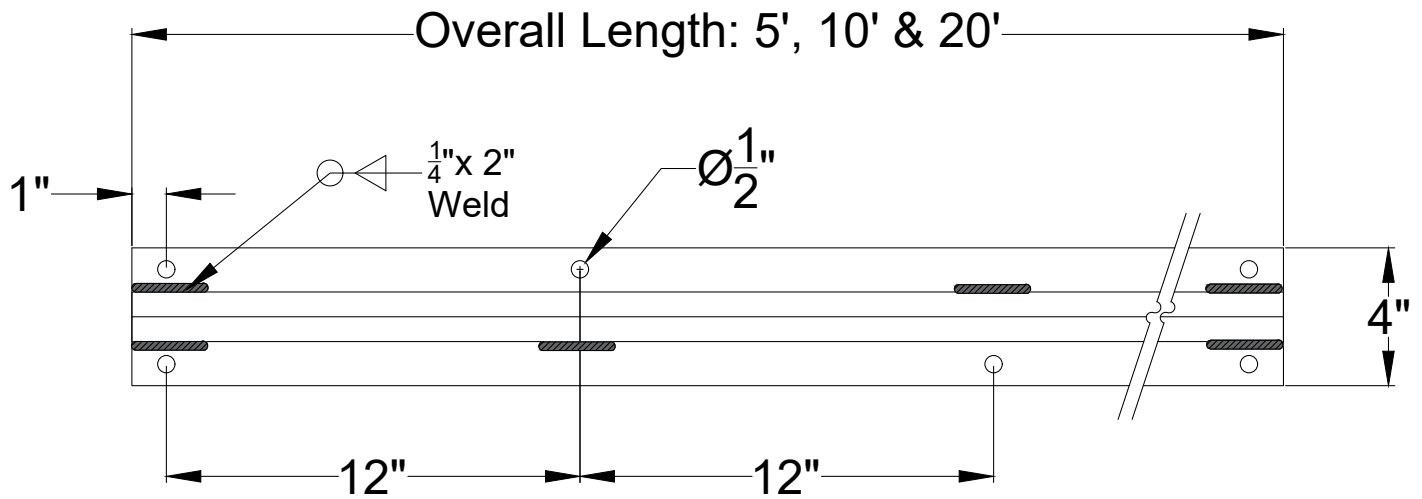

Technical Data

Facility	Data	
Weight	5 foot	24.5 lbs
	10 foot	49 lbs
	20 foot	98 lbs
Ground Plate	1/4" galvanized plate	
V Track	1/4" gauge 1" galvanized angle iron	
Finish	Hot-dipped galvanized	

Ordering Details

Product	Part #
5' Heavy V track	9916.001G
10' Heavy V track	9916.002G
20' Heavy V track	9916.003G
5-year warranty	

About TORXUN

TORXUN engineers architectural-grade products for vehicle access controlled systems. Everything is produced in Tracy, California.



50 Sloan Court, Tracy, CA 95304
(888) 491-4283



Precision Handcrafted
in Northern California
from U.S. Steel.