

Lock Guard



Features

- Meticulously welded and finished for long life and function
- Easy weldable assembly for easy installation into new or existing pedestrian gate
- 24" high, 12" half-moon wide and 4" deep for complete surround of lock lever and unencumbered lever access
- Prevents opening the gate with wire or reach through
- ADA compliant design
- Made in the USA with USA steel



TORXUN Lock Guard

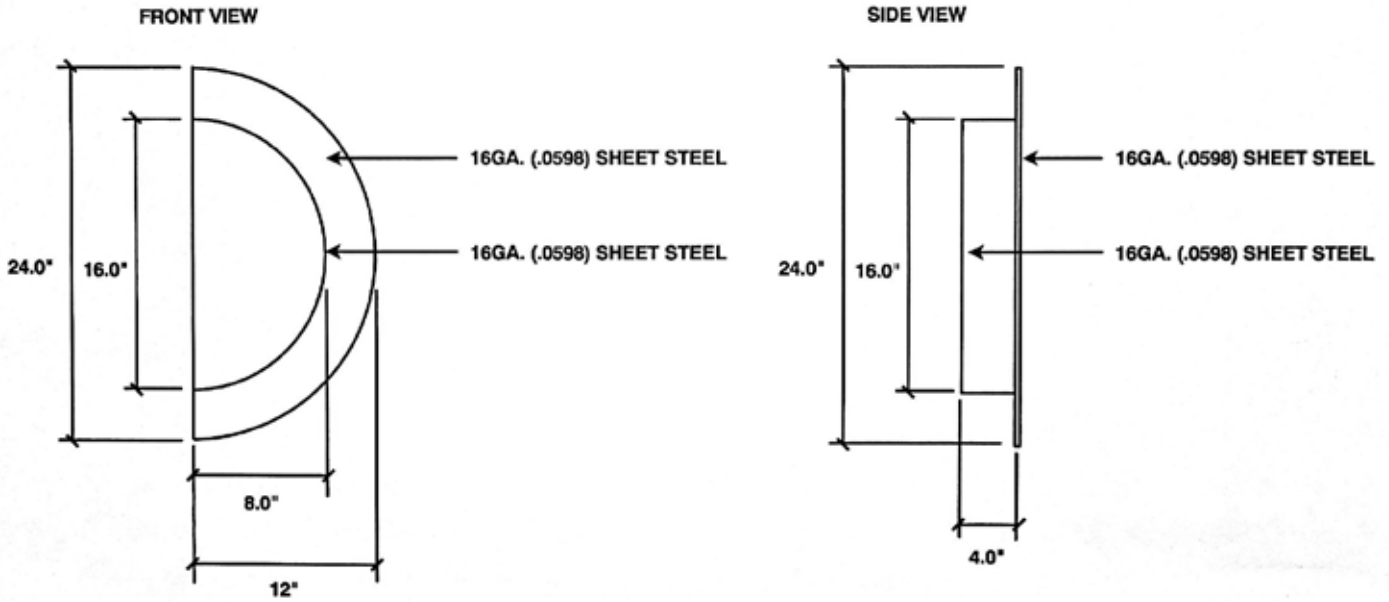

Technical Data

Facility	Data	
Sheet metal	16 GA	
Handle Guard	Height	16"
	Width	8"
	Depth	4"
Flat plate dimensions	24" x 12"	

Ordering Details

Product	Part #
Black powder coating	9912.001P
No coating	9912.001R

Other finishes available.
Please call.

About TORXUN

TORXUN engineers architectural-grade products for vehicle access controlled systems. Everything is produced in Tracy, California.



50 Sloan Court, Tracy, CA 95304
(888) 491-4283



Precision Handcrafted
in Northern California
from U.S. Steel.